



420 EAST THIRD ST. PIQUA, OH. 45356  
 PHONE (513) 773-2442 TELEX 288081  
 FAX: (513) 773-2238

# SERIES CS

700  
 Rev. 3/84

## Close Coupled Turbine Pumps

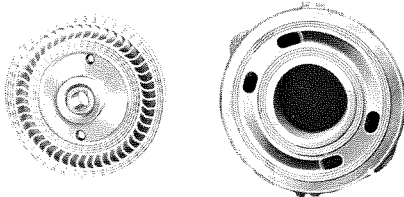
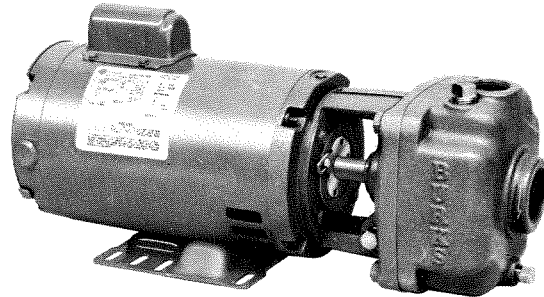

BURKS exclusive, unique regenerative type turbine pumps are designed to handle clear water and many other non-abrasive, lower viscosity liquids on high pressure, low capacity applications with the greatest possible efficiency.

BURKS is the only turbine pump with Life-Lok® External Impeller Adjustment feature that allows re-adjustment of impeller without disturbing piping, disassembling pump or replacing parts. Gives up to 40% longer service life than turbine pumps of other designs.

### QUALITY FEATURES

- Self-Priming
- Compact, space-saving size
- No coupling – eliminates misalignment problems
- Dependable carbon/ceramic mechanical shaft seal for temperatures to 225°F.
- Bronze impeller with Monel blades – the only moving part
- Bronze raceway with cast-in vortex pockets – will not vapor lock
- #303 Stainless Steel pump shaft
- Easy to service
- Every pump factory tested
- Available Bronze fitted, all Bronze, Stainless Steel

### PERFORMANCE AND SELECTION

*Catalog No.		H.P.	Tappings		TOTAL HEAD														
					PSI Feet	8.6 20	17.2 40	26 60	43.3 100	54.1 125	64.9 150	75.8 175	86.6 200	97.4 225	108.3 250	119.1 275	130 300	140.1 325	151.6 350
1-Phase	3-Phase		Suct.	Disch.	CAPACITY IN G.P.M.														
<b>1725 RPM</b>																			
34CS5M	334CS5M	1/3	1 1/4"	1"		5.8	4.9	4.3	3.3	2.8	2.4	2.1	1.8	1.6					
34CS6M	334CS6M	1/3	1 1/4"	1"		7.8	6.9	6.3	5.2	4.6	4.1	3.7	3.3						
54CS6M	354CS6M	1/2	1 1/4"	1"		7.8	6.9	6.3	5.2	4.6	4.1	3.7	3.3	2.9	2.6	2.3			
34CS7M	334CS7M	1/3	1 1/4"	1"		10.4	9.4	8.5	7.2	6.5									
54CS7M	354CS7M	1/2	1 1/4"	1"		10.4	9.4	8.5	7.2	6.5	5.9	5.4							
54CS8M	354CS8M	1/2	1 1/4"	1"		12.2	11.3	10.4	9.0	8.2									
<b>3450 RPM</b>																			
10CS5M	310CS5M	1	1 1/4"	1"		11	10.6	10.1	9.3	9	8.5	8.2	8	7.7					
15CS5M	315CS5M	1 1/2	1 1/4"	1"		11	10.6	10.1	9.3	9	8.5	8.2	8	7.7	7.5	7.4	7.2		
10CS6M	310CS6M	1	1 1/4"	1"		16	15.2	14.5	13.5	12.8									
15CS6M	315CS6M	1 1/2	1 1/4"	1"		16	15.2	14.5	13.5	12.8	12.4	12	11.5	11	10.7				
20CS6M	320CS6M	2	1 1/4"	1"		16	15.2	14.5	13.5	12.8	12.4	12	11.5	11	10.7	10.5	10.1		
15CS7M	315CS7M	1 1/2	1 1/4"	1"		20.5	19.6	19.5	17.3										
20CS7M	320CS7M	2	1 1/4"	1"		20.5	19.6	19.5	17.3	16.5	16	15.3	14.7						
	330CS7M	3	1 1/4"	1"		20.5	19.6	19.5	17.3	16.5	16	15.3	14.7	14.2	13.7	13.3	12.8		
20CS8M	320CS8M	2	1 1/4"	1"		26.5	25.5	24.6	23	22									
	330CS8M	3	1 1/4"	1"		26.5	25.5	24.6	23	22	21.3	20.5	19.8	19.2					
	350CS8M	5	1 1/4"	1"		26.5	25.5	24.6	23	22	21.3	20.5	19.8	19.2	18.5	18	17.4		
	330CS9M	3	1 1/4"	1"		32.5	31.5	30.5	28.6	27.5	26.5								
	350CS9M	5	1 1/4"	1"		32.5	31.5	30.5	28.6	27.5	26.5	25.6	24.7	23.8	23	22.2	21.5		

NOTE: When pumping hot water over 180°F., check the NPSH available in the pumping system against the required pump NPSH shown on pump performance curves. Available NPSH must be greater than required NPSH.

Standard pump motors have open drip-proof construction and are rated with jet pump service factors for continuous duty operation at all ratings shown. Single phase motors are capacitor start-induction run with built-in overload protection. Three phase motors require a magnetic starter which provides full 3-leg overload protection. Failure to use the correct starter and overloads will void the warranty.

#### TEMPERATURES TO 500°F

Series CS pumps are available in a patented Jacketed Seal Cavity design for pumping hot oil, hot water and heat transfer fluids in common use in high temperature heating or cooling applications. Add suffix "J" to Catalog Number. Example: 15CS6MJ.

#### 4CS Series:

Single Phase motors are 115/208-230 Volt, 60 HZ, 1725 RPM

Three Phase motors are 208-230/460 Volt, 60/50 HZ, 1725/1425 RPM

#### CS Series:

Single Phase motors are 115/208-230 Volt, 60 HZ, 3450 RPM

Three Phase 1, 1 1/2 & 2 H.P.—208-230/460 Volt, 60/50 HZ, 3450/2850 RPM

Three Phase 3 & 5 H.P.—208-230/460 Volt, 60 HZ, 3450 RPM

# PERFORMANCE AND SPECIFICATIONS

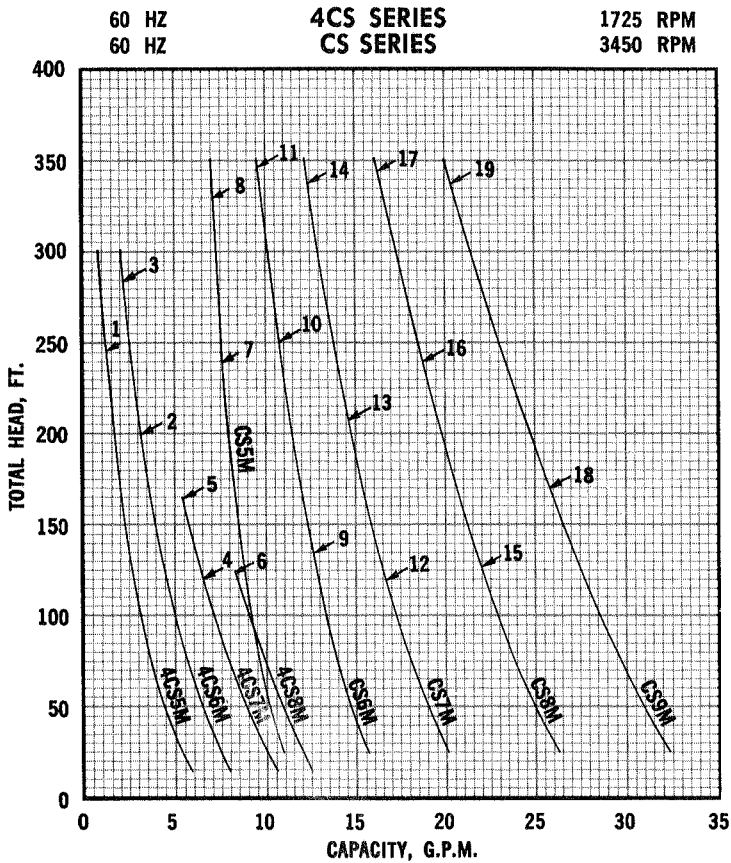

MAXIMUM HEAD*			
Symbol Number	H.P.	Catalog Number	
		1-Phase	3-Phase
1	1/3	34CS5M	334CS5M
2	1/3	34CS6M	334CS6M
3	1/2	54CS6M	354CS6M
4	1/3	34CS7M	334CS7M
5	1/2	54CS7M	354CS7M
6	1/2	54CS8M	354CS8M
7	1	10CS5M	310CS5M
8	1 1/2	15CS5M	315CS5M
9	1	10CS6M	310CS6M
10	1 1/2	15CS6M	315CS6M
11	2	20CS6M	320CS6M
12	1 1/2	15CS7M	315CS7M
13	2	20CS7M	320CS7M
14	3	—	330CS7M
15	2	20CS8M	320CS8M
16	3	—	330CS8M
17	5	—	350CS8M
18	3	—	330CS9M
19	5	—	350CS9M

\*For Standard Pumps with ODP Motors  
MAXIMUM INLET PRESSURE—100 PSI  
MAXIMUM WORKING PRESSURE—250 PSI

## MATERIALS OF CONSTRUCTION

Part	Bronze Fitted	All Bronze	Stainless Steel
Frame	Cast Iron	Bronze	#316 Stainless Steel
Case	Cast Iron	Bronze	#316 Stainless Steel
Impeller	Bronze (Monel Blades)	Bronze (Monel Blades)	#303 Stainless Steel
Raceway	Bronze	Bronze	#303 Stainless Steel
Shaft	#303 Stainless Steel	#303 Stainless Steel	#303 Stainless Steel
Shaft Seal	Carbon-Ceramic S.S.-Buna N	Carbon-Ceramic S.S.-Buna N	Carbon-Ceramic S.S.-Buna N

A strainer, approximately 20 mesh, should be installed on the suction side of the pump to prevent chips, scale or hard foreign particles from entering the pump and damaging the raceway and impeller.

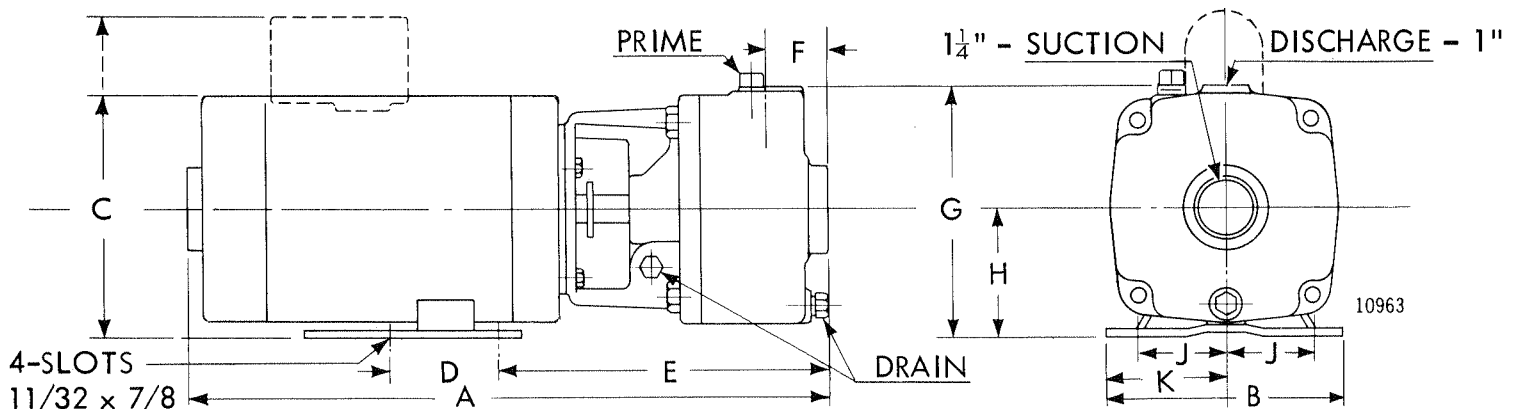

## DIMENSIONS

SERIES	HP	TAPPING		1 PH. A	3 PH. A	B	1 PH. C	3 PH. C	D	E	F	G	H	J	K
		SUCT.	DISCH.												
4CS	1/3	1 1/4	1	17 5/8	16 5/8	6 1/2	6 5/8	6 5/8	3	9	1 3/4	6 3/4	3 1/2	2 7/16	3 1/4
	1/2	1 1/4	1	17 5/8	16 5/8	6 1/2	6 5/8	6 5/8	3	9	1 3/4	6 3/4	3 1/2	2 7/16	3 1/4
CS	1	1 1/4	1	18 5/16	18 5/16	6 1/2	6 5/8	6 5/8	3	9	1 3/4	6 3/4	3 1/2	2 7/16	3 1/4
	1 1/2	1 1/4	1	19 1/16	19 1/16	6 1/2	8 13/16	6 5/8	3	9	1 3/4	6 3/4	3 1/2	2 7/16	3 1/4
	2	1 1/4	1	19 9/16	19 1/16	6 1/2	8 13/16	6 5/8	3	9	1 3/4	6 3/4	3 1/2	2 7/16	3 1/4
	3	1 1/4	1	—	19 9/16	6 1/2	—	6 5/8	3	9	1 3/4	6 3/4	3 1/2	2 7/16	3 1/4
	5	1 1/4	1	—	20 15/16	6 1/2	—	6 5/8	3	9	1 3/4	6 3/4	3 1/2	2 7/16	3 1/4